

# FLEX NEON CON LENTI

IP67 Flexible optical

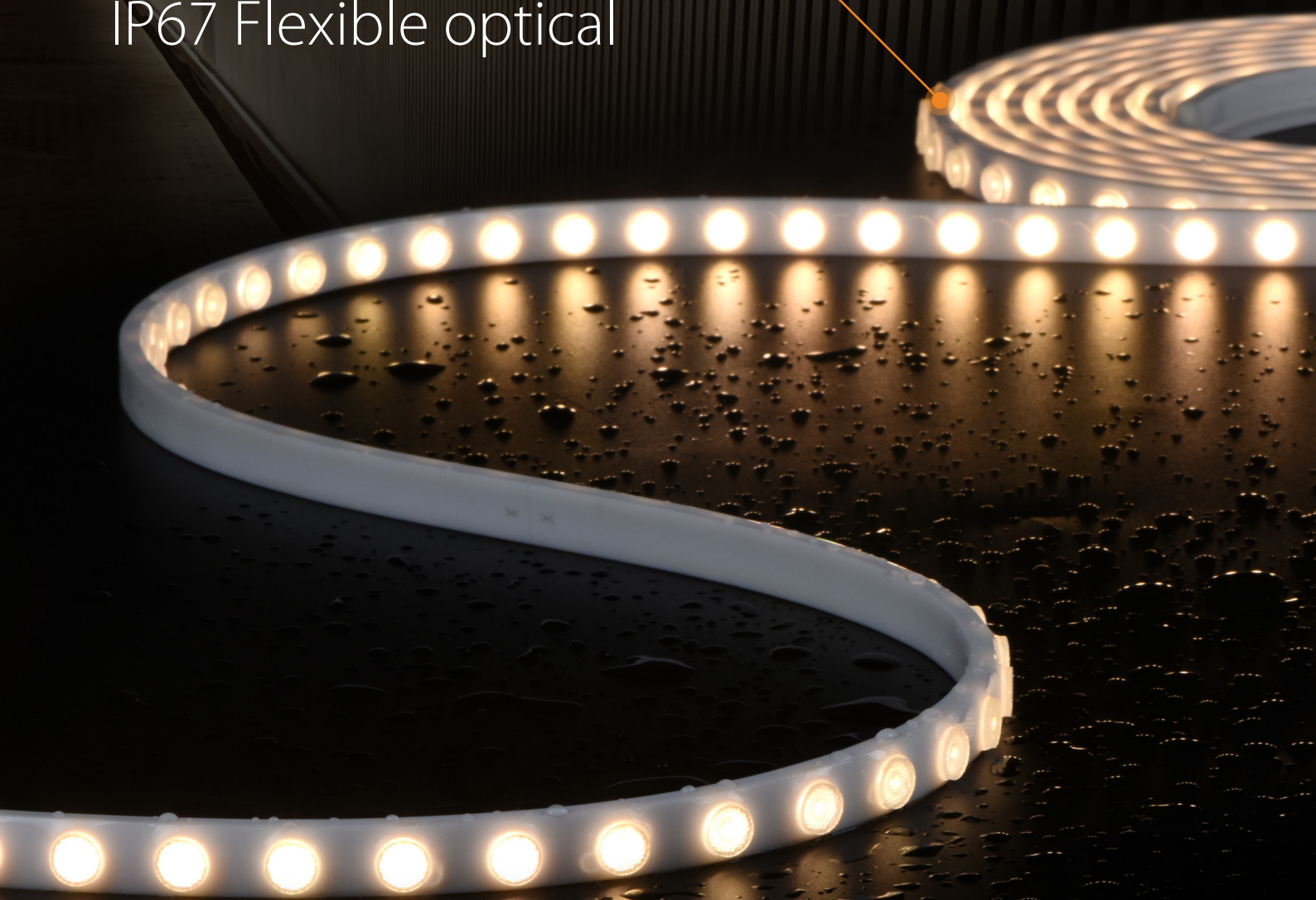

Multiple  
beam angle



Multiple  
color options



IP67  
waterproof



Adjustable  
mounting channels

# Flex neon con lenti IP67



## Flex wall washer light

Optical light design in Flexible and Linear solutions for task lighting and wall washer application.



## Multiple beam angle

Beam angles of 15°, 30°, 45°, 60°, 25x45°, 25x45x10° are available.



## IP67

IP67 waterproof  
Suitable for indoor and outdoor locations.

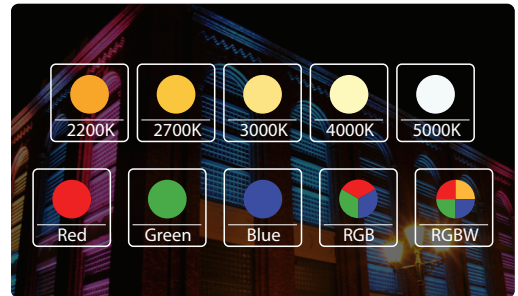

## Color options

Multiple colors available in Static white, RGB, RGBW and DMX RGBW.



## Adjustable mounting channels

Adjustable mounting clips with more possibility of light distribution.

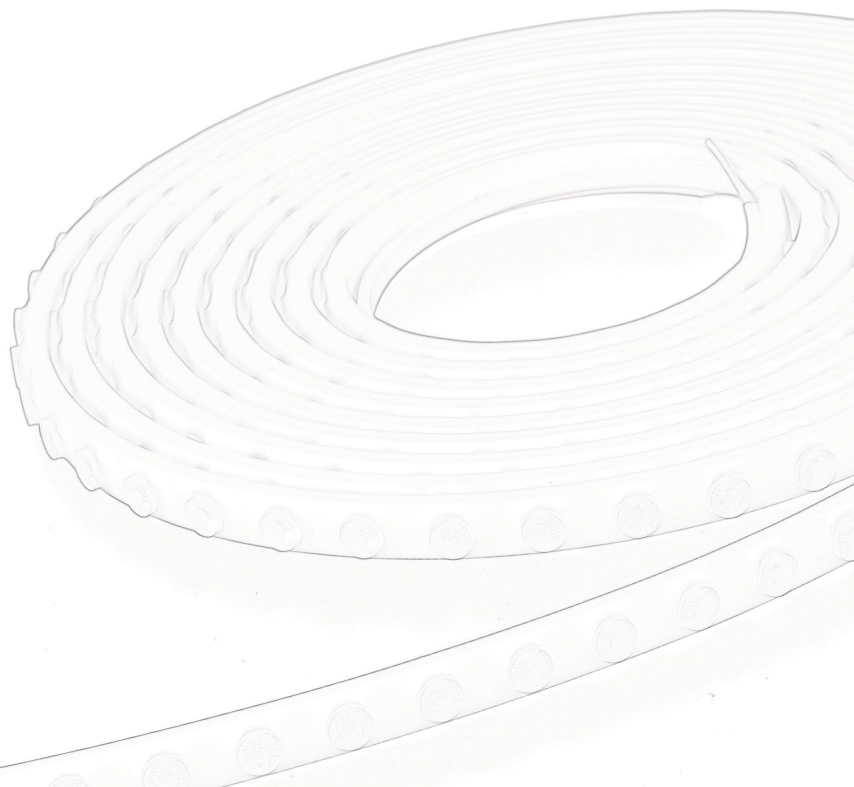

# Flex neon con lenti IP67 | Monocolore



● 2700K ● 3000K ● 3500K ● 4000K ● 4500K  
○ 5000K



<b>Models No.</b>	<b>AV0168CLU-E / AV0168NLU-E / AV0168WLU-E</b>	
<b>Power</b>	<b>18W/m (Max 24W/m)</b>	
<b>Width</b>	20mm	
<b>Lumen output</b>	1680 Lm/m	2700K AV0168WLU-E
	1780 Lm/m	3000K AV0168WLU-E
	1820 Lm/m	4000K AV0168NLU-E
	1860 Lm/m	5000K AV0168CLU-E
<b>MAXRUN</b>	5m	
<b>LEDs/m</b>	2835 48LEDs/m	
<b>Cut Length</b>	62.5mm (3 LEDs)	
<b>Voltage</b>	24 VDC	
<b>CRI (White)</b>	CRI 80+	
<b>CCT/Color</b>	2700K~5000K	
<b>IP Rating</b>	IP67	
<b>Dimmable</b>	Yes (PWM, DALI, 0/1-10V, Triac)	
<b>Operating temp.</b>	-35°C ~ 70°C	
<b>Beam Angle</b>	15°, 30°, 45°, 60°, 20x45°, 20x45x10°	
<b>Strip length/reel</b>	0.5m~5m	
<b>Lifespan</b>	50,000Hrs	

## Accessories

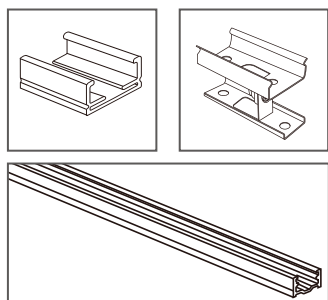

## Cut points

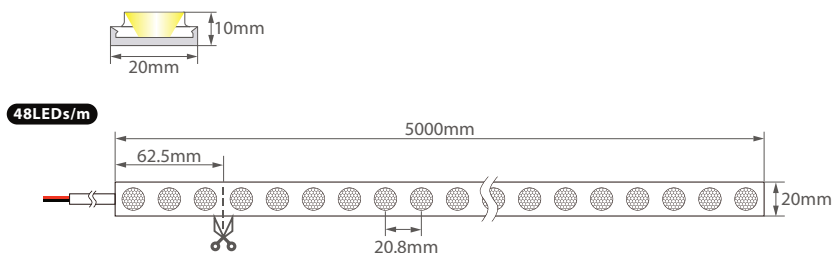

# Light Distribution Curve



## LUMINAIRE PHOTOMETRIC TEST REPORT

Test:U:24.000V I:0.8210A P:19.700W PF:1.0000 Freq:0Hz	
Lamp Flux:1683.69x1 lm	
	TYPE: Flex LED wall washer

DATA OF LAMP		PHOTOMETRIC DATA			
MODEL	LS-SW28U48-x-OF20	Imax (cd)	7078	S/MH(C0/180)	0.33
NOMINAL POWER (W)	19.7	LOR (%)	100.0	S/MH(C90/270)	0.35
RATED VOLTAGE (V)	24	TOTAL FLUX (lm)	1683.7	η UP, DN (C0-180)	2.5, 47.5
NOMINAL FLUX (lm)	1683.69	CIE CLASS	DIRECT	η UP, DN (C180-360)	2.5, 47.5
LAMPS INSIDE	1	η up (%)	5.0	CIBSE SHR NOM	0.00
TEST VOLTAGE (V)	24	η down (%)	95.0	CIBSE SHR MAX	0.30

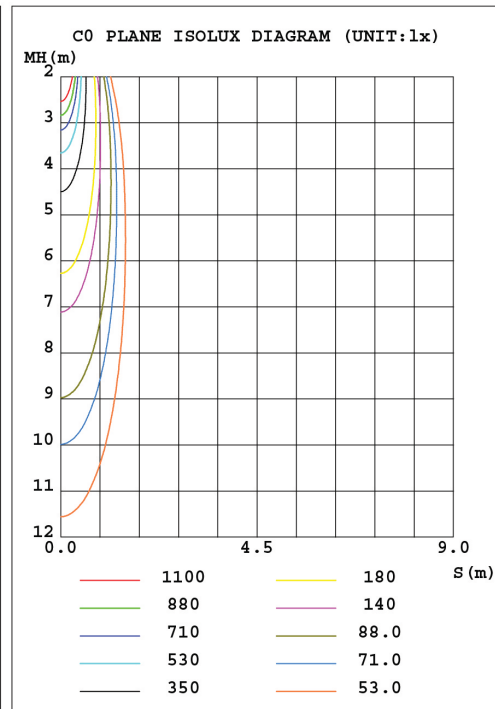
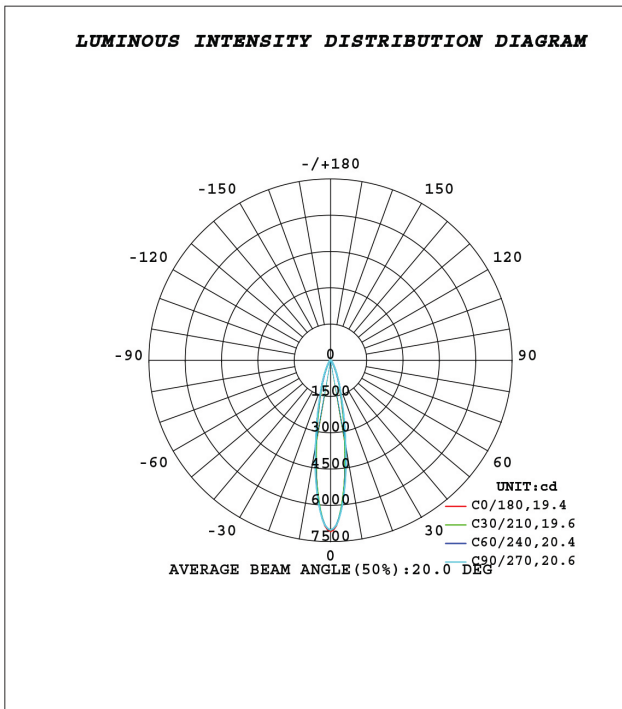

C Range: 0 - 360DEG  
 C Interval: 30.0DEG  
 Test Speed: HIGH  
 Temperature: 25.3DEG  
 Operators: DAMIN  
 Test Date: 2021-07-07

γ Range: 0 - 180DEG  
 γ Interval: 1.0DEG  
 Test System: EVERFINE GO-2000A\_V1 SYSTEM V2.00.443  
 Humidity: 65.0%  
 Test Distance: 8.000m [K=0.7063]  
 Remarks:

# Installation Diagram

## Installation with back tape

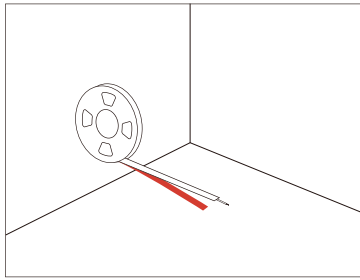

Remove the product from the packaging box and tear off the tape on the back.

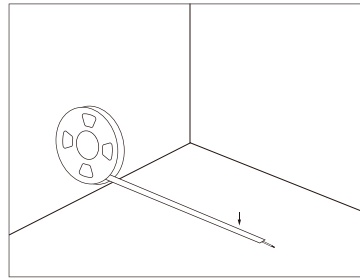

Install the product where you need it (ensure the wall is smooth), refer to the installation distance diagram for the specific glowing effect, and stick it firmly.

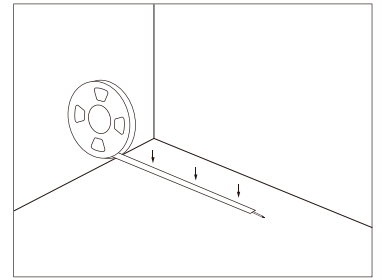

Connect the product to the low-voltage driver and energize it.

## Installation with stainless steel back tape

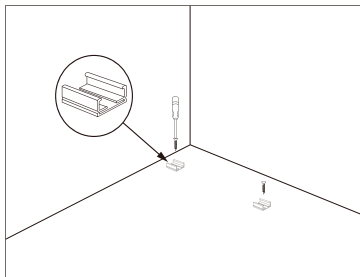

Remove the stainless steel mounting clips and screws from the packing box, and use a screwdriver to install these clips where needed.

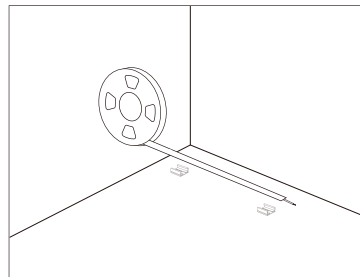

Take the light out of the box, then put the light into the clips and secured it (refer to the installation distance diagram for the specific glowing effect).

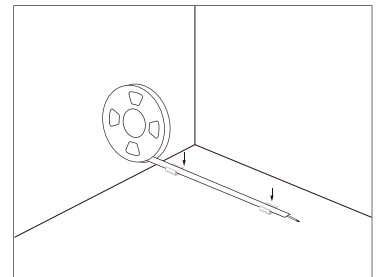

Connect the product to the low-voltage driver and energize it.

## Installation with Silicone Mountin Clip

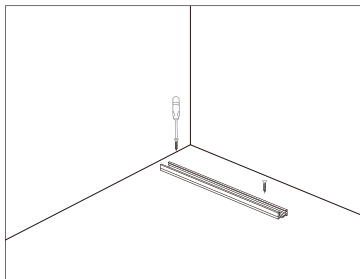

Remove the light, aluminum profile and rotating brackets from the box, and fix the rotating brackets to the needed position with a screwdriver.

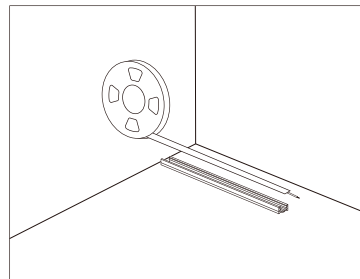

Put the light into the aluminum profile, and press the light down along the profile to ensure the light is tightly stuck into it. Then

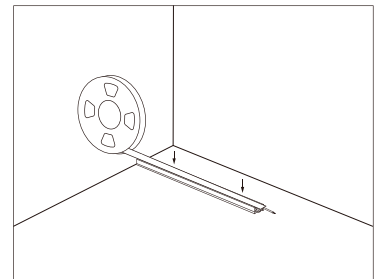

The specific glowing effect can be adjusted according to the needs of the application. After the installation, connect the light to the low-voltage driver and energize it.

## Installation with Aluminum Profile

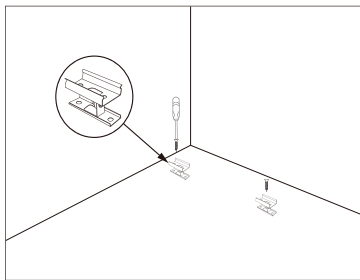

Remove the light, aluminum profile and rotating brackets from the box, and fix the rotating brackets to the needed position with a screwdriver.

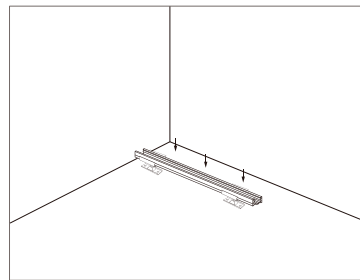

Put the light into the aluminum profile, and press the light down along the profile to ensure the light is tightly stuck into it. Then fasten the profile on the rotating brackets (according to the glowing angle requirements, the rotating bracket can be adjusted).

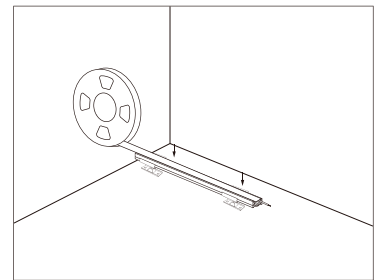

The specific glowing effect can be adjusted according to the needs of the application. After the installation, connect the light to the low-voltage driver and energize it.