

## 1. Product Features

- 100W LED emergency driver.
- Applicable to LED tunnel lamp, high bay light, flat lamp and other LED lamps.
- Voltage protection: wide voltage input AC85V-265V
- Overload protection: power over rated power 20% delay protection.
- Overload protection: timely protection when power exceeds 50% of rated power.
- Short circuit protection and no loading protection
- External test button and three-color LED indicator
- Battery: High capacity lithium ion battery with overcharge and over discharge protection.
- The battery adopts BYD balanced charging scheme ensuring the parameters of each cell are balanced.
- The patented control circuit is used in emergency driver, which makes it faster in conversion and a high efficiency of inversion.
- The SMT technology ensures consistency of excellent performance of each product.
- The emergency driver is small at size, compact in structure, convenient in installation and maintenance.

## 2. Battery Pack

- High temperature resistant batteries
- 18650 18.5V Lithium-ion battery pack
- Battery capacity is optional according to emergency time
- Simple plug-in connection

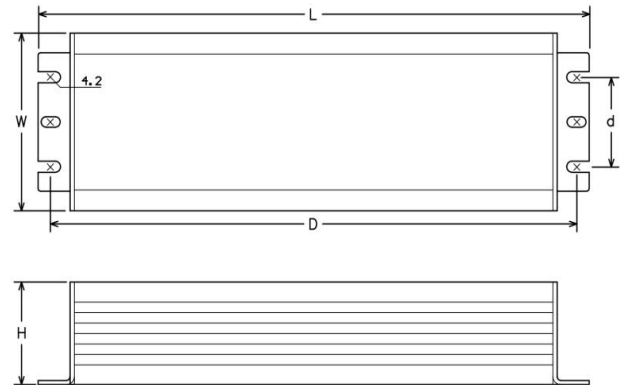

## Mechanical data

Product Item	AV0102JQL-E
Horizontal Installation Hole Spacing D	330±2 mm
Horizontal Installation Hole Spacing d	75 mm
Installation aperture	Ø 4.2 mm
Length * width * height	235/305/370x103x80 mm
Input line	17AWG×4C(180mm)
Output line	17AWG×3C(180mm)
Other line	24AWG×5C(350mm)
G.W.	3-4kg

### 3. Ordering Information

Product Item	AV0102JQL-E
Light Source Type & Watts	LED light, 10W-100W
Output Voltage	DC 230V
Emergency Power	10W-100W
Emergency Time	≥ 60/90/120 min
G.W.	15-20KGS/CTN
Package	1PC/BOX ; 5 BOX/ CTN

**4. Electrical parameters (25°C/70%RH, AC230V/50Hz, Rated load)**

Product Item	AV0102JQL-E
Rated Voltage	AC85-265V
Rated Frequency	50/60 Hz
Power Factor	≥0.95 (≥75%load)
Input Power	100W (Not including charging power)
Conversion Efficiency	≥90%
Charging Power	Max 20W
Charging Current	Max 1500mA
Battery Voltage	3.7V *5(lithium battery)
Battery Type	Li-ion
Conversion Time	≤0.05S
Charging Time	≤24h
Emergency Time	≥60/90/120 min
Output Voltage	DC 230V±5%
Output Current	0.3-1.5A
Emergency Power	10-100 W (MAX:120W)
Emergency Output	Main Output 100%
Overcharge Protection	≥24.50±0.1V Enter the Balanced Charging Mode from the Back , 25.50±0.1V Cut-off charging
Over Discharge Protection	17.25±0.1V
Short Circuit Protection	Current Limited Output, Automatic Recovery after Short Circuit Removal
Open Circuit Protection	Constant voltage output, shut down system after 3 seconds in emergency condition
Class	Class I
Overheat Protection	≥100±10°C , Automatic recovery after cooling
Ambient Temperature	-25-50°C
Shell Temperature	≤80°C
Storage Temperature	-25—50°C
Protection Level	IP30
Pressure Resistance	I/P-O/P:3750VAC, I/P - FG:2000VAC, O/P - FG:500VAC
Leakage Current	≤0.5mA
Insulation Resistance	≥100MΩ (DC 500V) I/P-O/P, I/P - FG, O/P - FG
Remark	If you have any other requests, please contact us for instructions.

5. Appearance size (Unit: mm)

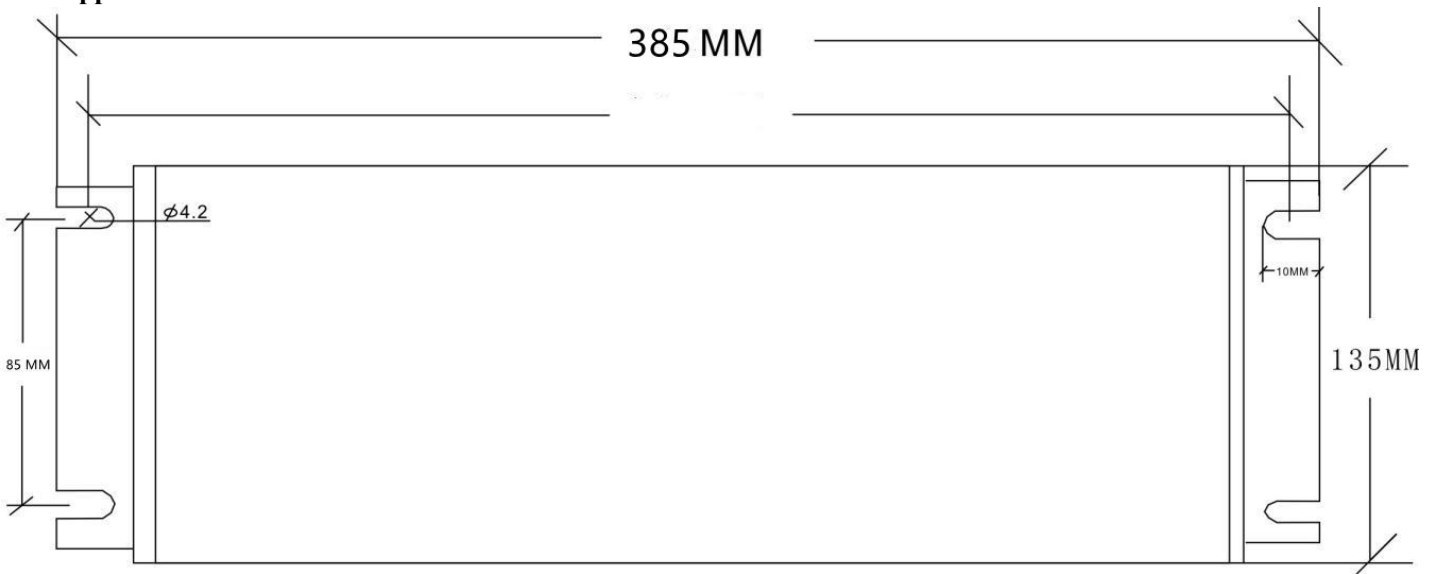

6. Installation wiring

A. WIRING DIAGRAMS (Drive internal)

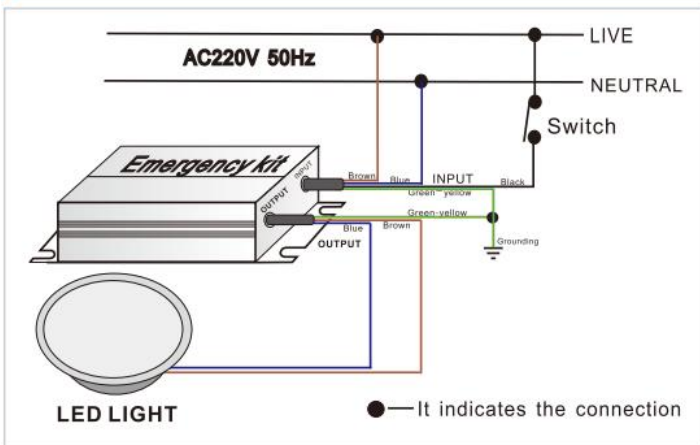

B. WIRING DIAGRAMS (Drive external)

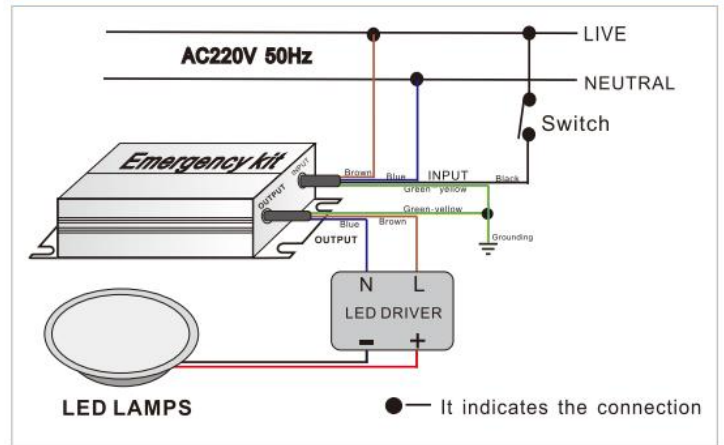

## Cautions for wiring

※Do not connect (indicator lamp, test switch line), (power LED output line) with each other

Power LED wiring should be as short as possible to increase losses, Recommended lamp connection using copper core wire less than 3 meters. The connection of signal lines such as indicator lamp and test switch should be less than 1 meter. Wall lighting switch (between L and K), wiring must be on the same phase line. In order to use the control device safely and avoid damaging the control device, do not connect two phases to the controller. LED light source is polar light source. Do not misconnect polarity to avoid malfunction and extra loss. In order to use this control device correctly and safely, please connect correctly according to the wiring diagram strictly.

### 6.1 、 Recommendation for Installation

This product has a good heat treatment unit, in order to ensure product performance, reliability and service life, it should have good heat dissipation conditions and use environment. Battery packs should be kept away from heat sources, and it is important to ensure that the ambient temperature of the battery packs is within the allowable range. In order to ensure good heat dissipation, the bottom of the product should be well installed on the metal floor or away from the heat source, so that the temperature of the working environment of the product can be controlled within the allowable range. The correct method of mounting on the metal plate is shown in the figure below on the right.

### 6.2 、 Electromagnetic interference.

- Do not cross-wire the power input line and the light connection line.
- As far as possible, do not parallel the long distance wiring between the power input line and the lamp connection line.

When parallel wiring, the distance between 5 and 10 cm should be reserved.

- Do not put the power input line too close to the control device.
- Bending lamp connection.
- Shorten the distance between the input line of the power supply and the control device.
- When running in parallel, the connection line between the power input line and the lamp should be as short as possible.

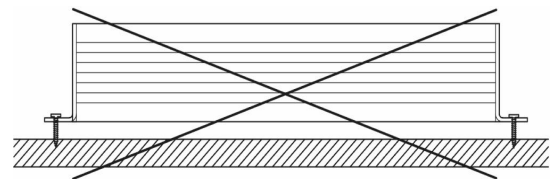

### 6.3 、 Suggestion

- When the light source is replaced at the end of its life, please turn off the power supply and operate it.
- If there is no lamp for a long time and the temperature is too high, please turn off the AC power .
- Can not overwrite power supply.

## INSTRUCTION

### 7.1 Introduction:

Firstly, thank you for using our emergency driver, which owns perfect design, high quality material and wide usage. Ensuring you to use this emergency driver safely and correctly, please read and understand the following instruction.

This emergency driver accords with GB17945-2010, it is suitable for all 50-200W LED lamps with internal IC driver(This device CANNOT be used for the LED lights with RC driver.). It can be used in public places to ensure LED lights work normally when power fail suddenly because of fire and earthquake and etc.. This emergency driver would not influence its environment and power around when it works.

### 7.2 Structure and operating principle:

The device housing of this emergency driver adopts good-quality steel models with powder coating. It is of novel appearance and low weight and being convenient to install, so you can rest assure its safety. It mainly includes housing, PCB and battery etc. Its battery adopts Li-ion battery with

long lifespan. Its PCB adopts automatic SMT technology, uses IC control design in charging/discharging and power supply part.

PCB uses fully automatic SMT technology, PCB core use TDN258828NJH and 3525 IC chips which are especially for emergency lights and Li-ion battery protections. PCB circuit has the complete protection designs for over charging/discharging,output Short Circuit, Open Circuit,input/output reverse connection.

Operating principle: the emergency driver is being charged when AC power works, when fully charged, the circuit will protect the battery from over being-charged, and the emergency is standing by as soon as the battery is fully charged. The battery will be changed to supply power while the AC power fails and make the LED lights work and light up the way for people to escape and dismiss in order.

**7.3.The symbol of its model:**

**7.4.Technical Term:**

AC Power Status---working status of LED lamp and emergency driver when AC power is OK.

Emergency Status---working status of LED lamp and emergency driver when AC power fails.

Changing time to emergency---time needed for emergency driver to supply power when AC power is off.

**7.5 Main features:**

Working voltage	AC 85V-265V	Battery	18.5V	IP rank	IP30
Changing time of emergency	≅ 2s	AC fuse	5A 250V	Luminous flux	≅ 1000LM
Output power while emergency	10-100W MAX:120W	DC fuse	20A 50V	Type of lamp	LED Lamp
Emergency time	60/90/120 mins	Working temperature	-10°C-50°C	Size	235/305/370x103x80 mm

**7.6. Battery and light source Usage and Replacement:**

***Warning: As the inner PCB includes 220V/50HZ high voltage, so it must be unloaded/opened ONLY by professional technicians.***

7.6.1.Battery: in normal occasion, please change battery when discharging time is less than 40 minutes after being charged for 24 hours or battery leaks.

While changing battery, Cut off the AC power, take apart the lamp, removing the battery plug and replace the old one with new battery of same specification,then the driver will be OK. Usually the lifespan of battery can last for more than 3 years.

***Note: The positive and negative of battery should not be connected reverse, and we should avoid directly short-circuit the battery. Explosion will be caused if using unmatched battery. Please abide by local rules when discarding old battery.***

2.Light source: 10-100W LED lamps with internal IC driver, please replace it with the same light source if light source is broken or its brightness is not enough. LED light's brightness in emergency status is the same as the one of AC Power Status.

**7.7 Installation Usage and Notes**

7.7.1. Before installation, please read and understand this instruction carefully 2.Usually it should be installed at stairs, corridor and the ceiling, not for outside environment.

7.7.2 The AC power supply of this emergency driver should be controlled by an stand-alone light switch, NOT influenced by the other switches.

7.7.3 Please note that its working voltage is 85V-265V AC power,47-63Hz. It would be broken if connected with 380V high voltage

7.7.4 If its indicating lights can't work as usual, or if turn on the switch of the LED light,the LED light do not work, the AC power should be cut off immediately and maintain the emergency driver.

7.7.5 Meaning of light color:

Green-AC power status; Red-charging status;

Blue-emergency status

### 7.8. Installation, Test and Maintenance

1. This emergency driver is Surface-mounted type, which has two installation holes. Putting a tapping screw of 4MM on the surface according to its installation size, and then fix the emergency driver, then it is OK. It can be on the surface of the fuel material.

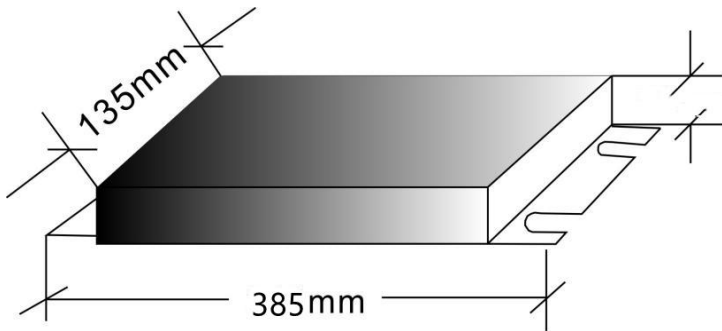

(Picture 1)

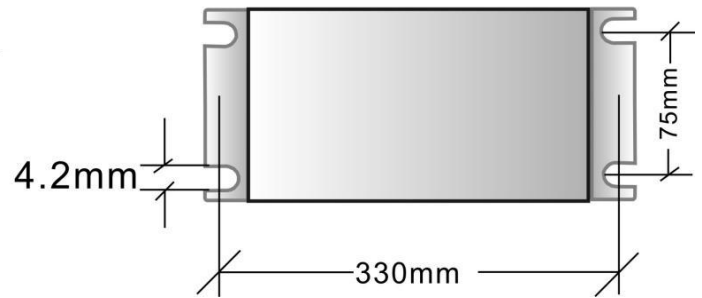

( picture 2)

Note: Picture 1 is the size of product; and the distance between two installation holes is 220/285/360 mm, just as picture 2 shows

2. It should be connected according to the wiring diagram on the emergency driver's surface strictly.

3. When connecting to AC power, see if the LED light works normally, at this time, green indicating light is on. At the same time, red indicating light would be on too, until the battery is fully charged. Two status of LED lamp:

a. Turn on the switch of the LED light (the wire from the 3rd connection end on the driver is connected with the Live wire from AC power), the LED lamp is on;

b. Turn off the switch of the LED light (the wire from the 3rd connection end on the driver is disconnected with the Live wire from AC power), the LED lamp is on;

4. Press the test button, the emergency driver enters the status of simulation of power failure. At this time, the indicating light of main power (green) and charging (red) is OFF, while the emergency indicating light (blue) is on, it is in emergency status. After loosing the button, it will return to AC power status again.

5. Cut off the emergency driver's AC power input switch, the LED lamp will be in emergency status; at the same time, the blue indicating light is on.

6. Cut off the LED lamp's connection to the emergency driver in emergency status, the emergency driver will stop supplying power, the emergency indicating light would be off.

Finishing installation after ensuring all is normal after testing. After testing the above steps, if OK, installation is finished.

7. While in the environment of 3 phases 4 wires, the Live wire of the LED light switch and the input Live wire of emergency driver must be from the same phase.

8. Keeping a record of maintenance and maintaining the emergency driver and LED lamp regularly. Checking regularly to ensure its lifespan and usage.

**7.9. Solution for problems**

Problems	analysis	Solution	remark
1.Green light not working	1.Something wrong with driver	Check driver	
	2.green light is broken Or circuit is disconnected	Check circuit or changing green light	
2.Red light is off	1.not being charged	Check the charging circuit or battery	
	2. red light is broken or circuit is disconnected	Checking circuit or changing red light	
	3.Battery is fully charged	Disconnecting the main power supply, make the LED light work in emergency status for 30 minutes, make the LED light return to work in AC power status again	
3.Blue light is off	1.The battery is open circuit or the battery is broken	Checking battery	
	2.LED light power is more than rated power.	Reduce the LED light power to less than 50W	
	3.The LED light is not matched.	To use the LED light with IC driver.	
	4,The LED light is open circuit or short circuit.	To check if the LED light is connected OK or if the LED light is broken.	
	5,Output/Input connection is reverse.	To check the wiring.	

**7.10 Package, shipping and storage**

7.10.1. Quantity and specification, please find the signs on packing;

7.10.2. Check if there are any broken emergency drivers in the carton, and please do not use any broken ones or out-of-shaped ones,if found any, DO NOT use them.

7.10.3. If the emergency driver is not used for over 3 months, it should be connected to AC power for full charging and discharging (after charging the battery for 24 hours, then discharge the battery until LED lamp is completely OFF. Then keep the emergency driver work with AC power for 24 hours and put it in dry ventilated places.

**Waring: don't open this device without professional instruction if you are not a professional technician. Otherwise, we will not assume any responsibility.**